

02780□

## Motorcycle Battery Specification

YB10L-B2 (12V11AH)

### Specifications

Nominal Voltage		12V
Rated capacity (10-hour rate)		11Ah
Dimensions (±2mm)	Total Height	145mm
	Height	145mm
	Length	134mm
	Width	90mm
Weight Approx.		2.70kg
Acid Volume		0.78L
Charge Current		1.1A
Max Charge Voltage		
Terminal Type		8

### Characteristics

Capacity 25°C	10-hour rate(1.1A to 10.5V)	11.0Ah
	5-hour rate(2.2A to 10.2V)	9.35Ah
	1C(11.0A to 9.6V)	4.95Ah
	3C(33.0A to 9.6V)	3.96Ah
Internal Resistance (at 1KHz Approx.)		7.0mΩ
Cold Cranking Amperes (-18°C) SAE/EN		140A/120A
Operating Temperature Range	0°C to 40°C	Charge
	-15°C to 50°C	Discharge
	-15°C to 40°C	Storage
Charge Retention (Shelf Life) at 20°C	1-month storage	92%
	3-month storage	90%
	6-month storage	80%
Life Expectancy (Cycle Use)	100% depth of discharge	200 cycles
	80% depth of discharge	225 cycles
	50% depth of discharge	500 cycles
Standby Use	3~5 years	
Case Material	PP	
Separator		

### Outer dimensions (mm)

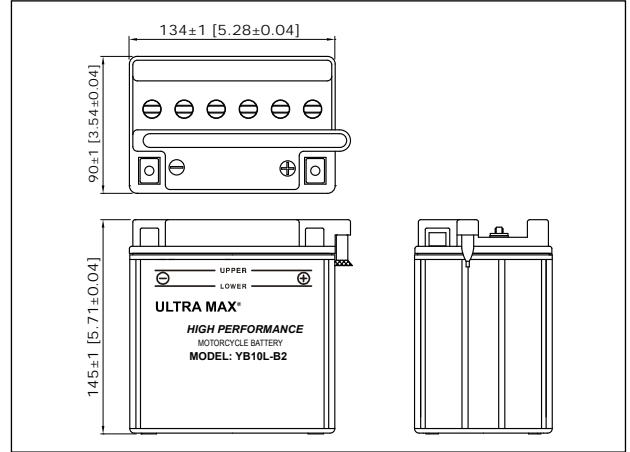

### Terminal Type (mm)

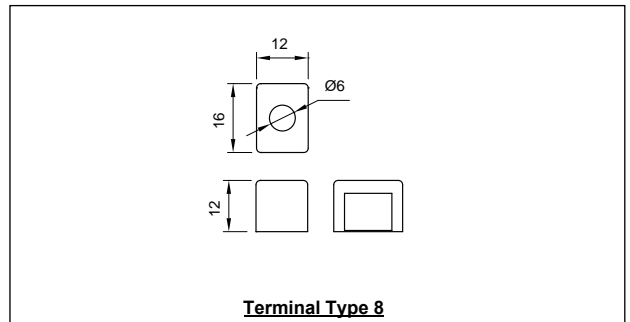

### Cell Assembly Layout

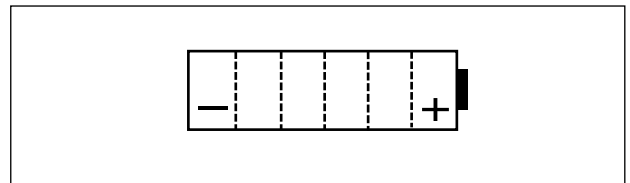

### Discharge Curves at 25°C

